

WORKSHOP MANUAL

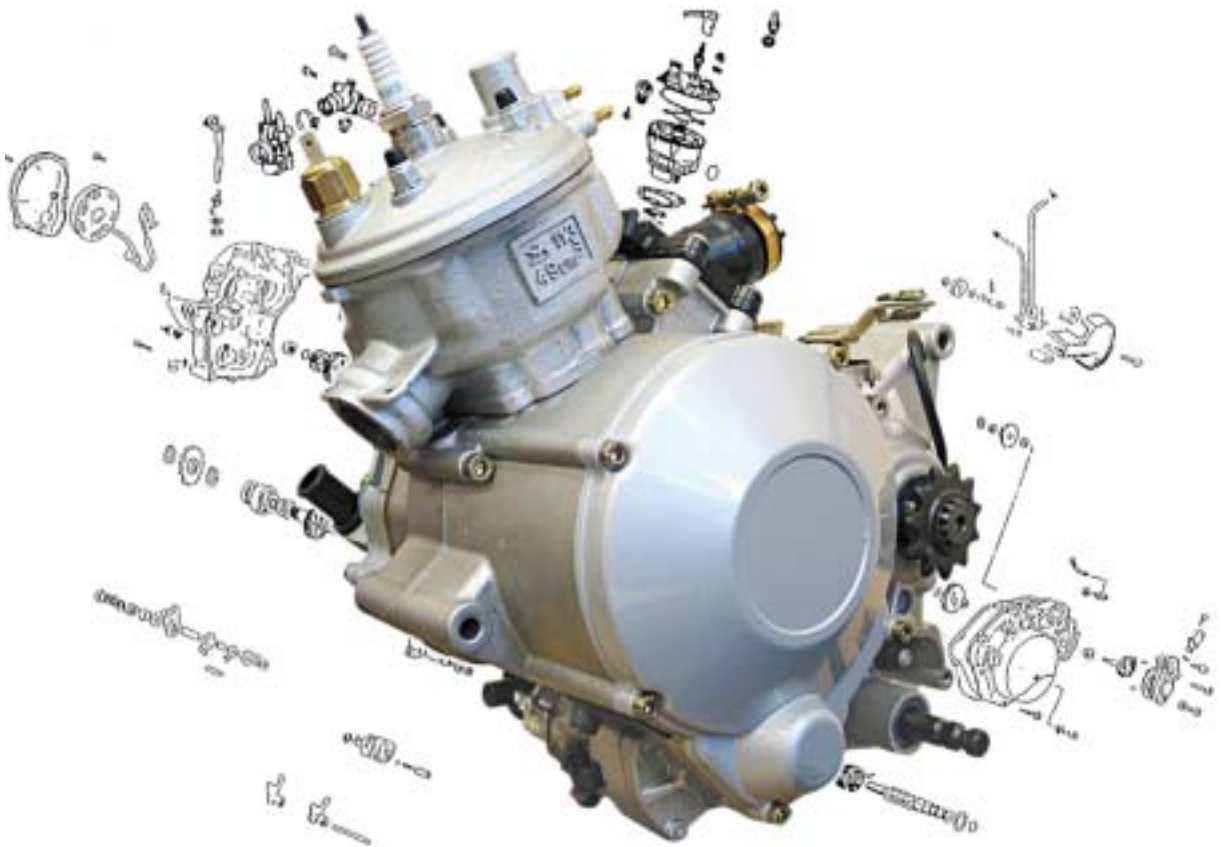

50 cc ENGINE MULTI-SPEED

CONTENTS

CONTENTS	2
CHARACTERISTICS	4
Characteristics.....	4
Capacities.....	4
Engine markings.....	4
SPECIAL IMPORTANT POINTS	5
Oil and fuel.....	5
TIGHTENING TORQUES	6
Tightening torques.....	6
SPECIAL TOOLS	7
DISASSEMBLY	9
Putting the engine on the stand.....	9
To remove the magneto flywheel.....	9
To remove the stator.....	10
To remove the starter motor (depending on model).....	10
To remove the gearbox output pinion.....	10
To remove the clutch cover.....	11
To remove the clutch.....	12
To remove the crank assembly and balance shaft pinions.....	14
To remove the inlet manifold and valve.....	14
To remove the cylinder head/cylinder assembly.....	15
To remove the piston.....	15
Removal of the thermostat.....	16
Removal of the temperature sensor.....	16
To open the engine casings.....	17
To remove the gearbox and the selector system.....	18
To remove a primary or secondary shaft pinion.....	20
To remove the balance shaft.....	21
To remove the crank assembly.....	21
Checking the crank assembly.....	22
REFITTING SPECIFIC COMPONENTS	23
To fit the crank assembly bearings.....	23
To fit the box output seal.....	24
To fit the selector shaft seal.....	24
To fit the clutch lever seal.....	24
To fit the balance shaft.....	25
To fit the crank assembly.....	25
To fit the gearbox.....	25
To fit the left side casing.....	27
To check the piston.....	29
To check the piston rings.....	29
To fit the piston.....	29
To fit the cylinder.....	30
To fit the cylinder head.....	30
To fit the right side O-ring.....	31
To fit the crank assembly and balance shaft pinions.....	31
To fit the clutch.....	33
To adjust the clutch control lever.....	35

CONTENTS

To fit the starter system (depending on model) and the clutch cover.....	35
To fit the magneto flywheel.....	36
MISCELLANEOUS OPERATIONS	37
To remove the water pump	37
To fit the water pump	37
To remove the oil pump and its drive pinions	38
To fit the oil pump	38

CHARACTERISTICS

CHARACTERISTICS

Characteristics

Engine	Single cylinder 2-stroke with balance shaft
Cooling	Liquid
Bore x stroke	40.3 x 39 mm
Cubic capacity	49.7 cc
Max. power output	1.82 kW at 5250 rpm
Max. torque at	5250 rpm
Gearbox	6-speed
Clutch	Oil bath multi-disc with manual control
Oil pump	Mikuni ESOP-03
Spark plug	NGK BR9ES
Magneto flywheel	Ducati 85 W
Starter motor	Ducati
Carburettor	Dell'orto PHBN 12

Capacities

Gearbox	0.75 L. SAE 10W30
---------	----------------------

Engine markings

Engine type	AM6
-------------	-----

SPECIAL IMPORTANT POINTS

SPECIAL IMPORTANT POINTS

Oil and fuel

This engine is designed to run on 95 or 98 unleaded fuel only

The separate lubrication system oil to use is Esso 2T Spécial recommended by the manufacturer.

Note:

Petrol is highly inflammable, do not smoke in the working area and avoid proximity to flames or sparks.

Work in a clear and well-ventilated area.

TIGHTENING TORQUES

TIGHTENING TORQUES





Tightening torques

Cylinder head	1.8 m.daN
Cylinder casings	1.1 m.daN
Transmission cover	1.1 m.daN
Water pump	1.1 m.daN
Inlet manifold	1.1 m.daN
Crank assembly pinion	7.5 m.daN
Balance shaft pinion	6 m.daN
Clutch cover	7.5 m.daN
Clutch pressure plate	0.5 m.daN
Clutch thrust bearing locknut	2.7 m.daN
Starter motor	1.1 m.daN
Rotor	5.2 m.daN
Stator	0.3 m.daN
Magneto flywheel cover	0.4 m.daN
Gearbox drain plug	1.8 m.daN
Spark plug	2.5 m.daN

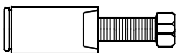
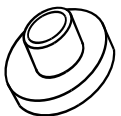
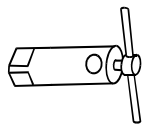
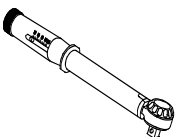
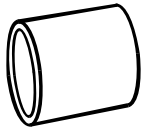
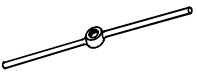
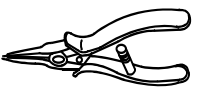
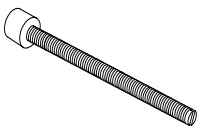
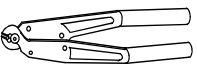

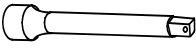
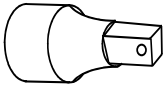

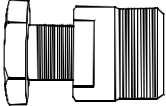
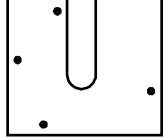
SPECIAL TOOLS

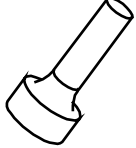
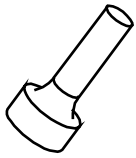
SPECIAL TOOLS

	Tool N°	Description	Used with
	64706	Casing extractor and opening tool	Casing opening plate + pin
	64710	Shoulder locator	64706
	64765	Engine support	Engine support adapter
	68994	Torque wrench 8 Nm to 54 Nm	Extension 752235 adapter 752236
	69098	Protective cap large model	754003
	69104	Wing nut	750069 + 64711 + 64712 + 64754
	69117	Exterior circlip pliers	
	750069	Stud Ø10 pitch 125	69104
	750539	Tie-wrap pliers	

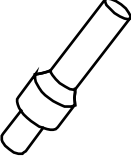
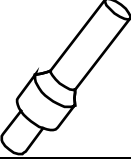
	752000	Piston circlip pliers	
	752235	1/2 extension	69802 or 753977
	752236	1/2-3/8 adapter	69802 or 753978
	752237	Adjustable pin wrench	
	753411	Magneto flywheel extractor	68007
	753708	Casing opening plate	64706
	753709	Engine mount adapter	
	753726	Crank assy lip seal fitting tool for primary transmission side	
	753728	Selector shaft lip seal fitting tool	

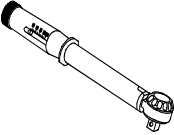
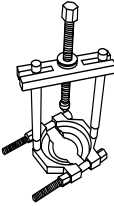
TOOLS

	753729	Water pump lip seal fitting tool	
	753730	Clutch lever lip seal fitting tool	
	753731	Clutch locking tool	
	753977	Torque wrench 30 Nm to 150 Nm	Extension 752235 adapter 752237
	755585	Bearing extractor tool	
	755813	Valve unit safety Allen key	

DISASSEMBLY

Putting the engine on the stand

- Fit the engine to adapter P/N 753709
- Lock the engine to the adapter using the 2 spring pins
- Put the assembly on stand P/N 64765 clamped in the jaws of a vice

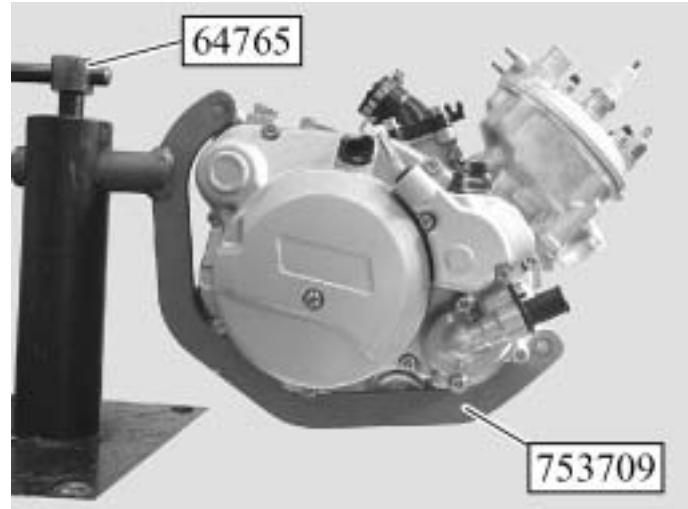

To remove the magneto flywheel

- Remove the magneto flywheel cover
- Remove the paper gasket
- Hold the rotor (1) with the pin wrench P/N 752237
- Remove the nut

Depending on the model, the rotor acts as the starter ring

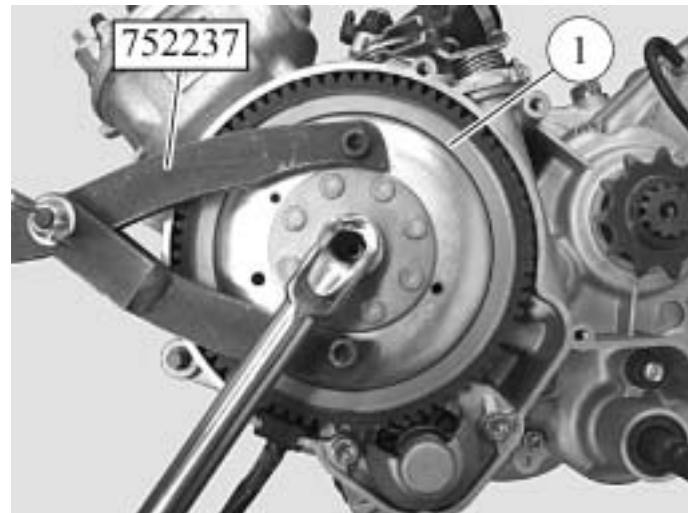

- Tighten flywheel extractor P/N 753411 on the rotor
- Lock the flywheel extractor and turn the thrust bolt until the rotor is released

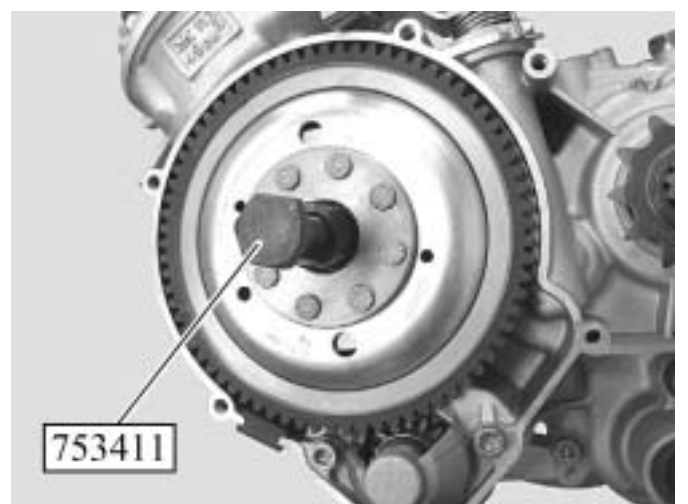

DISASSEMBLY

To remove the stator

- Remove the three fixing bolts (1) from the stator plate and stator
- Remove the stator plate and stator assembly

Note: We recommend tapping the bolts with a hammer and drift to facilitate slackening
The 3 bolts must be renewed once removed

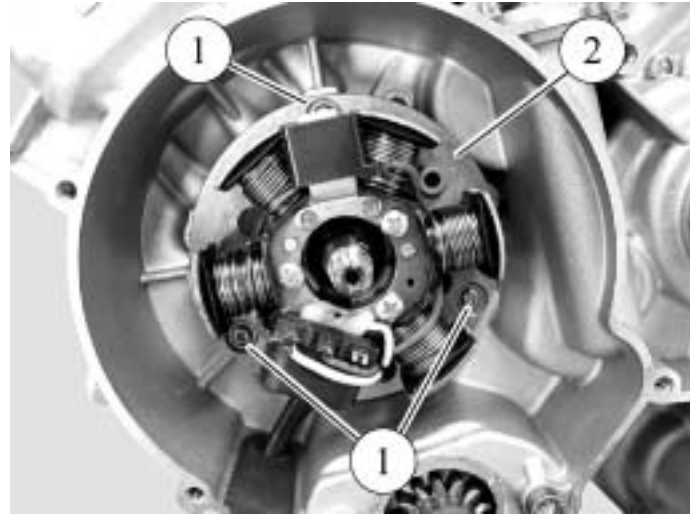

To remove the starter motor (depending on model)

- Remove the starter motor (2) three fixing bolts (1)
- Remove the 2 spring pins which lock the engine to the adapter
- Move the engine along the adapter guides to remove the starter motor
- Re-fit the 2 spring pins

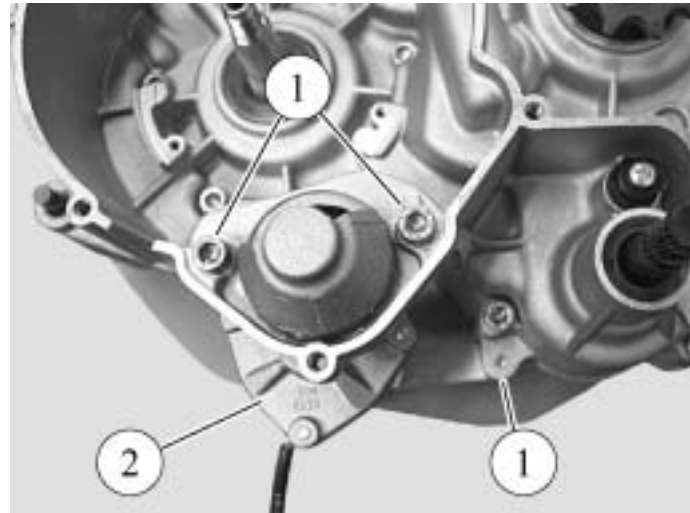

To remove the gearbox output pinion

- Remove the circlip (1) using pliers P/N 69117
- Remove the pinion (2)
- Remove the second circlip

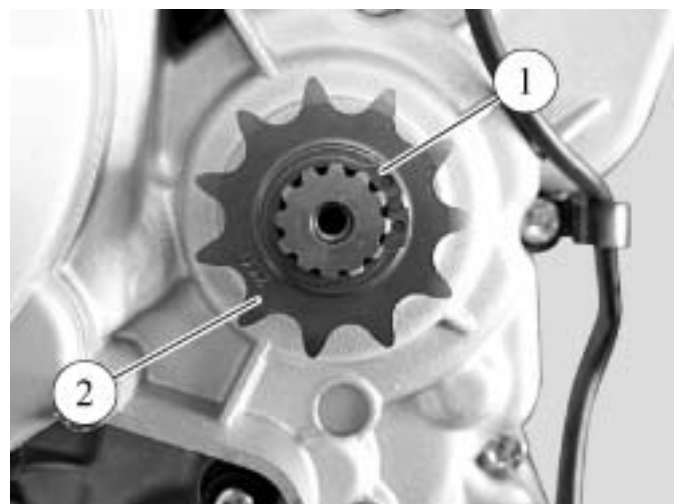

DISASSEMBLY

To remove the clutch cover

- Remove the kickstart pedal securing bolt (depending on model)
- Lightly operate the kickstart pedal and hold it in position
- Slacken off the kickstart shaft thrust bearing (1) and release the kickstart pedal to relax the spring
- Remove the kickstart pedal

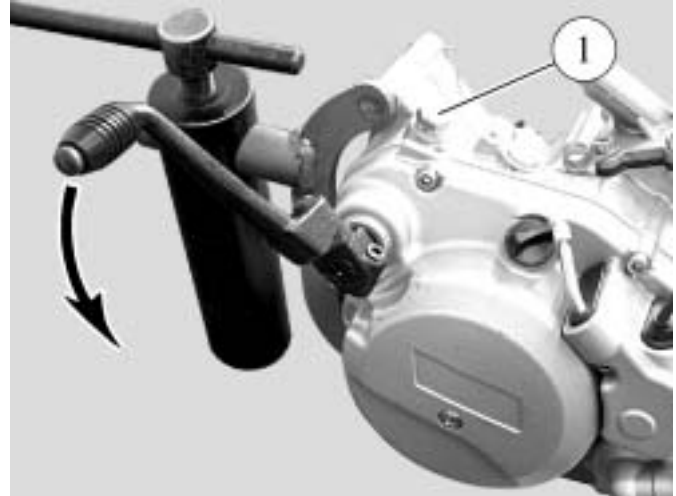

Note: Use a recipient to recover the box oil

- Remove the bolt (2) in order to drain off the gearbox

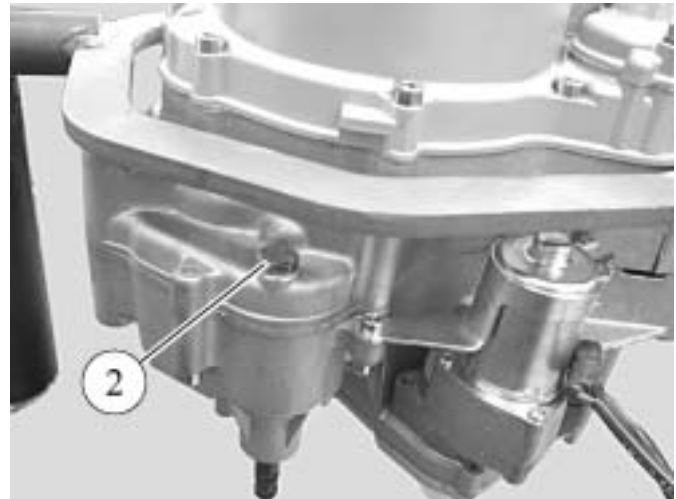

- Remove the cover 8 fixing bolts
- Remove the cover
- Remove the two centring pillars and the paper gasket



DISASSEMBLY

To remove the clutch

- Remove the four bolts and spring (1) from the pressure plate (2)
- Remove the pressure plate

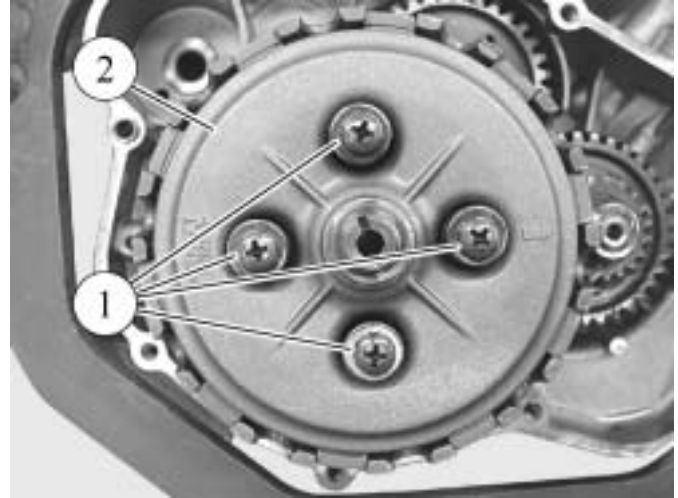

- Remove the assembly (3) of 4 lined discs and 3 smooth discs
- Withdraw the primary shaft:
 - the piston (4)
 - the ball (5)
 - the thrust rod (6)

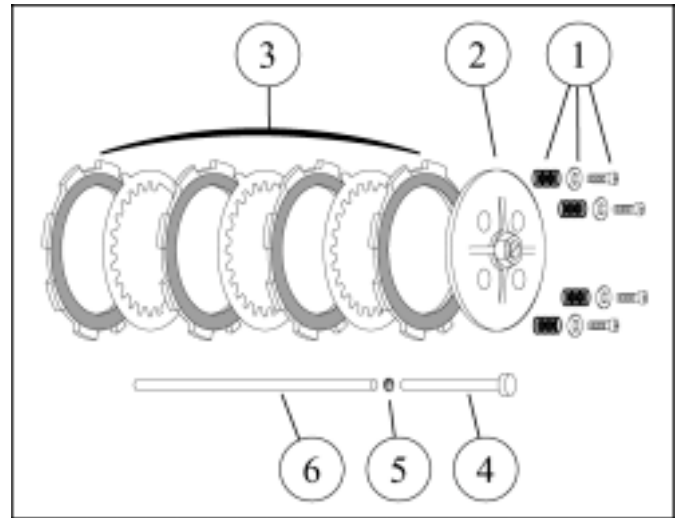

- Remove the clutch operating lever (7) with its spring (8) and its washer (9)

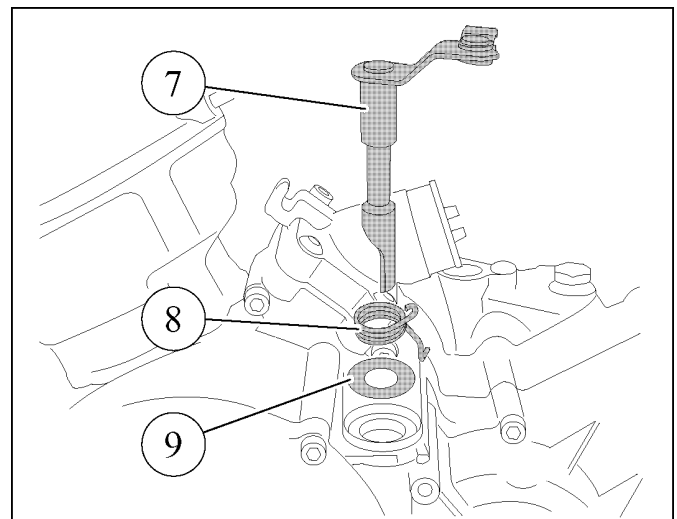

DISASSEMBLY

- Fold down the clutch nut (10) lockwasher tab (11)
- Lock the clutch main shaft (12) with tool P/N 753731
- Remove the nut and the washer

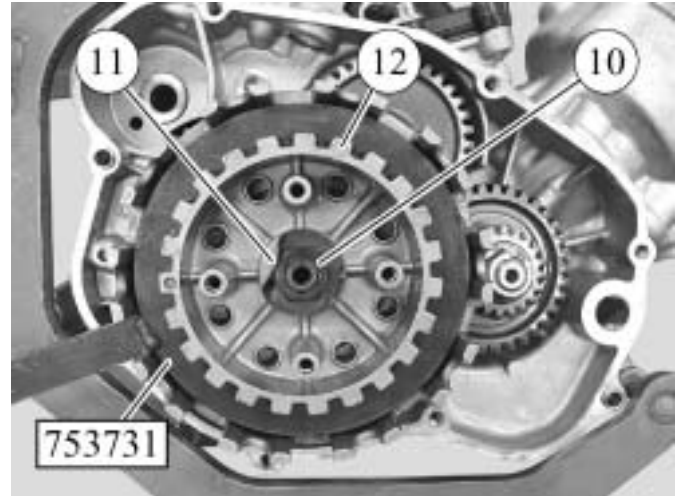

- Remove the clutch main shaft (12), the splined bush (13), the cover (14), the plain washer (15) and the tapered washer (16)

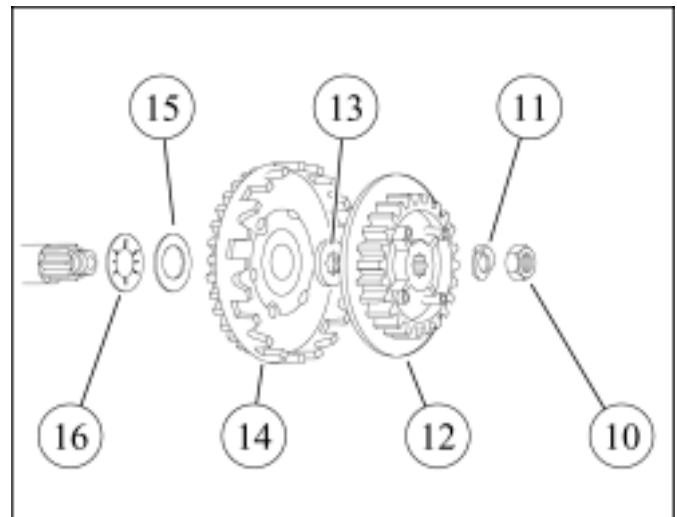

DISASSEMBLY

To remove the crank assembly and balance shaft pinions

- Lock the balance shaft using a bolt (A) inserted into one of the threaded holes
- Turn the balance shaft pinion (1) to bring the bolt into contact with a ribbing in the case
- Remove the crank assembly nut (2)
- Remove the balance shaft nut (3)

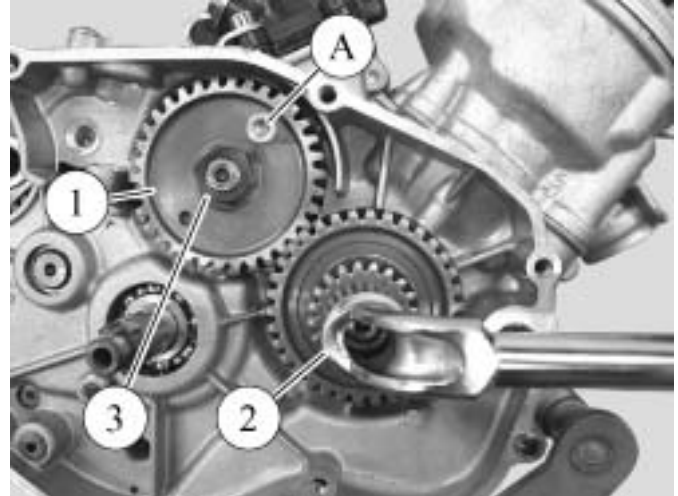

- Remove the 2 pinions (20 and 34 teeth) and the key (4) from the crank assembly
- Remove the 34-tooth pinion and the key (5) from the balance shaft



To remove the inlet manifold and valve

- Remove the four inlet coupling bolts, two of which (1) are with the safety Allen key P/N 755813
- Remove the coupling and the inlet valve



DISASSEMBLY

- Check that the valve assembly blades and support are in perfect condition

Note: The position of the limiter must be 7 mm from the valve support

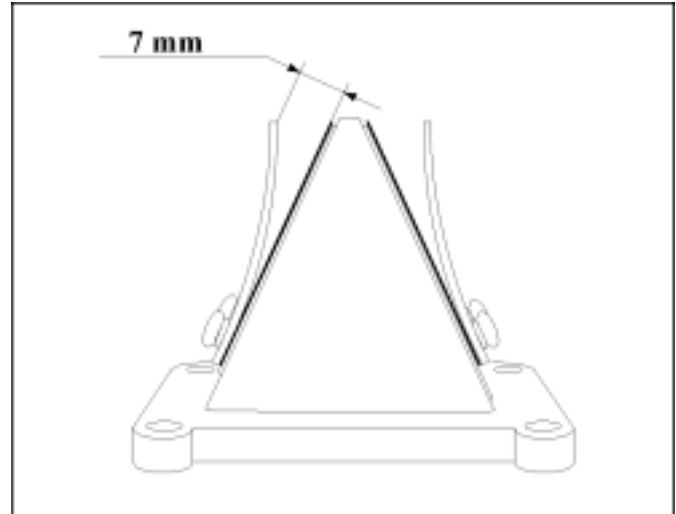

To remove the cylinder head/cylinder assembly

- Remove the spark plug
- Slacken off the cylinder head/cylinder 4 mounting nuts in the order shown, in 2 or 3 stages
- Remove the 4 nuts and washers
- Remove the cylinder head and the 2 O-rings
- Remove the cylinder and its bottom seal

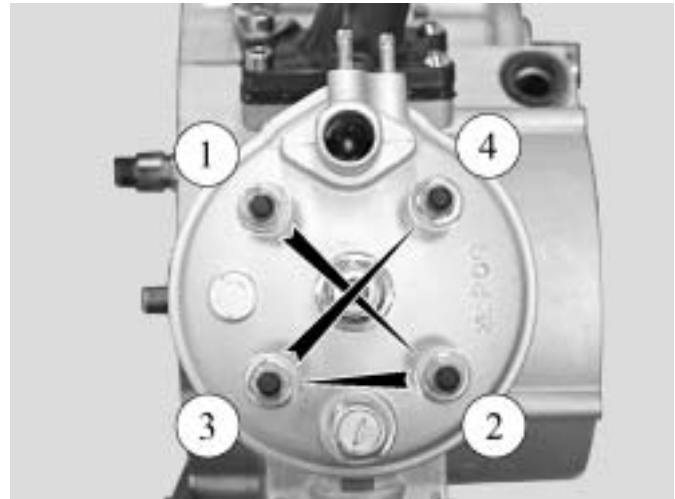

To remove the piston

- Remove one of the circlips (1) with pliers P/N 752000
- Remove the gudgeon pin
- Remove the piston
- Remove the needle bearing race from the connecting rod end

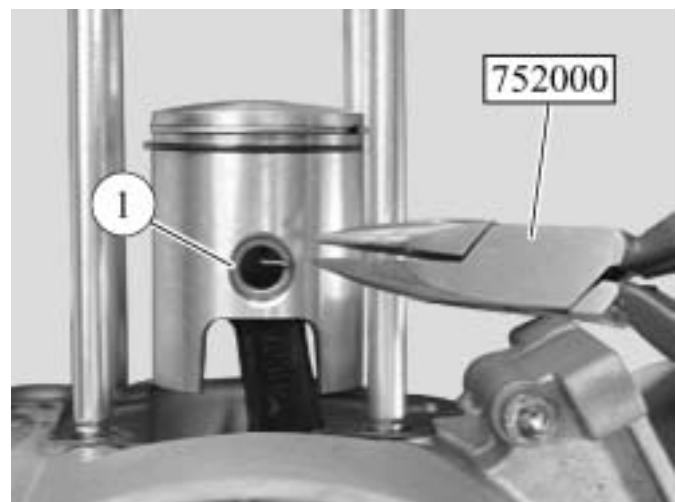

Removal of the thermostat

- Remove the thermostat (2) two bolts (1)
- Remove the thermostat

Note: When refitting, ensure that the degassing hole (A) is at the highest point

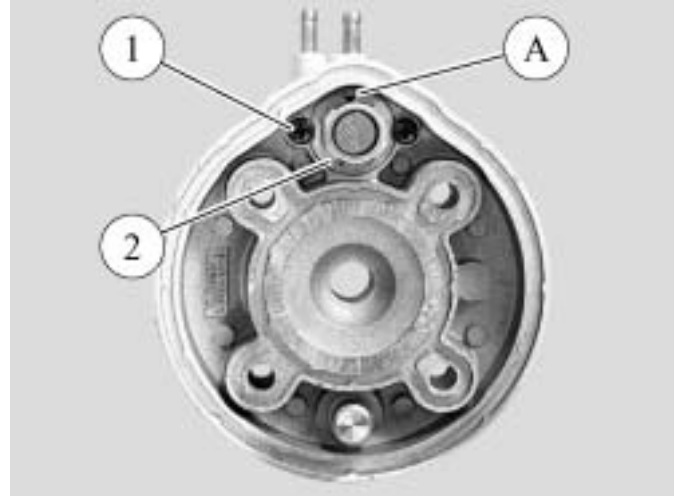

Removal of the temperature sensor

Note: The engine temperature sensor (1) seal is provided by a steel gasket



DISASSEMBLY

To open the engine casings

- Remove the left casing 13 securing bolts



- Fit the crank assembly protective cap P/N 68007
- Fit to casing with tool P/N 64706 fitted with plate P/N 753708

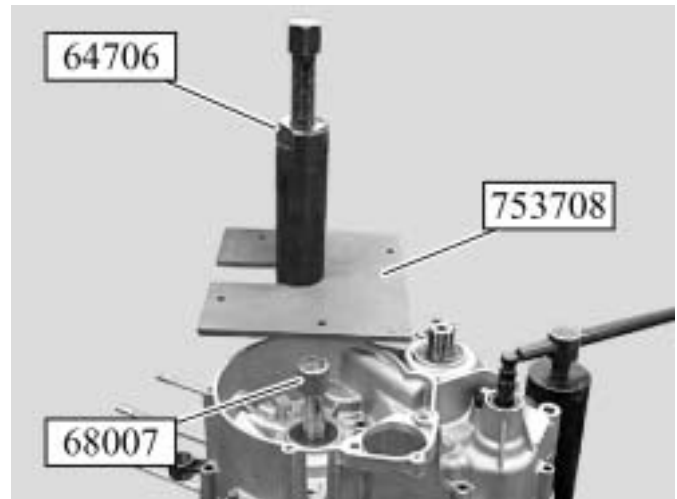

- Fix the assembly to the casing using four bolts (1)
- Remove the engine mount adapter 2 spring pins
- Tighten the tool centre screw until the casings separate

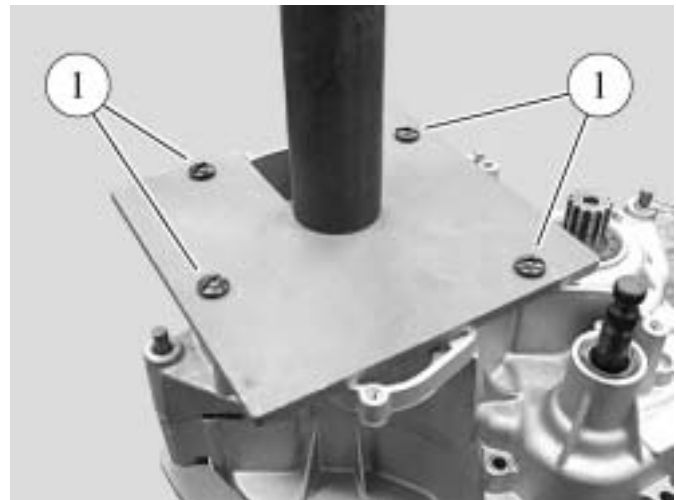

Note: When opening the casings, so that they open evenly, use a plastic mallet to tap alternatively on the ends of the secondary shaft and the speed selector

DISASSEMBLY

- To remove the left casing

Note: Recover the friction washers which may have been retained by the oil in the left casing

- Remove the 2 centring pins (2)
- Refit the engine mount adapter 2 spring pins

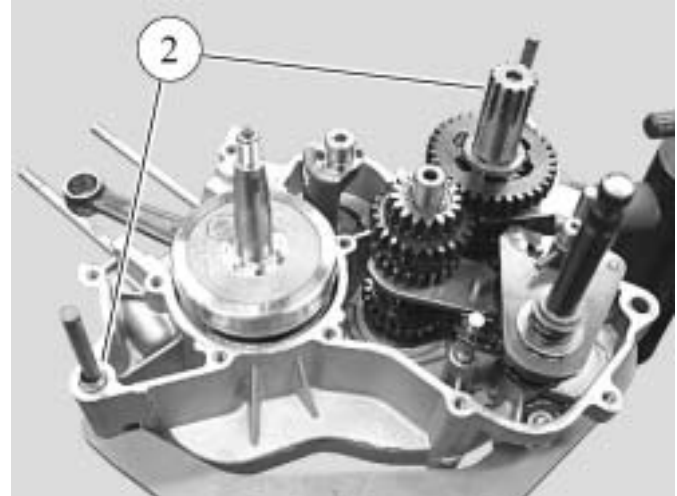

To remove the gearbox and the selector system

- Position the selector so that the mecanindus pin is positioned opposite the secondary shaft fork shaft



- Remove the selector shaft (1) fitted with its 2 friction washers

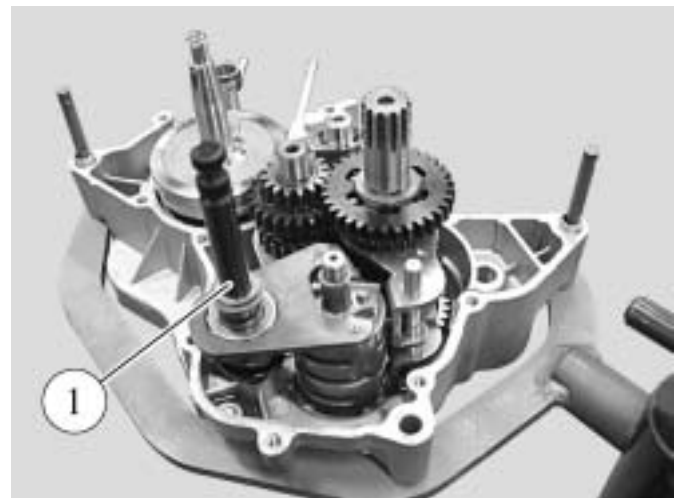

DISASSEMBLY

- Remove the fork shaft (2) from the secondary shaft
- Remove the upper fork (3) from the secondary shaft



- Turn the selector cylinder (4) to lower the primary shaft fork (5) into the cylinder lower groove
- Remove the selector cylinder
- Remove the secondary shaft 2nd fork (6)

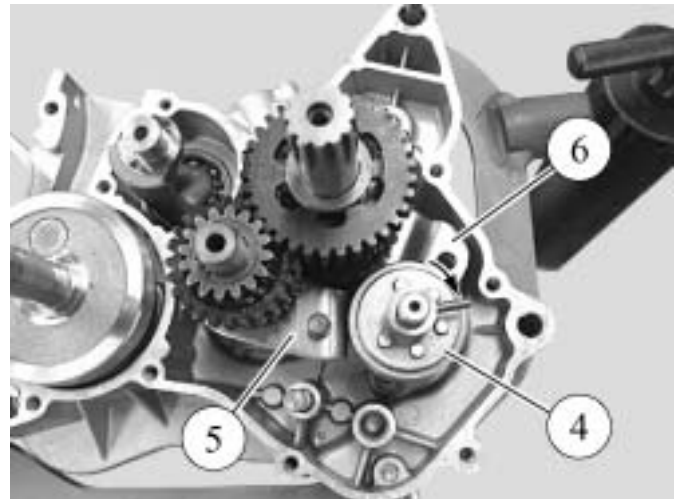

- At the same time, remove the secondary shaft and primary shaft assembly fitted with its fork

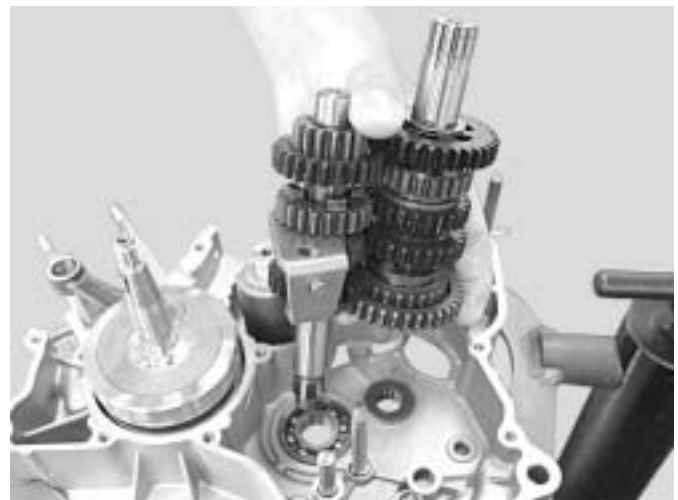

DISASSEMBLY

- Remove the friction washer (7) from the secondary shaft which due to the oil may have remained stuck in the right casing
- Remove the locking ball (8) and its thrust spring



To remove a primary or secondary shaft pinion

- Remove the circlips and pinions using circlips pliers P/N 69117
- When refitting, ensure each part is fitted in the right position and the right way round

1. Primary shaft with 1st gear pinion
2. 3rd and 4th gear pinion
3. 5th gear pinion
4. 2nd gear pinion
5. 6th gear pinion
6. Circlips

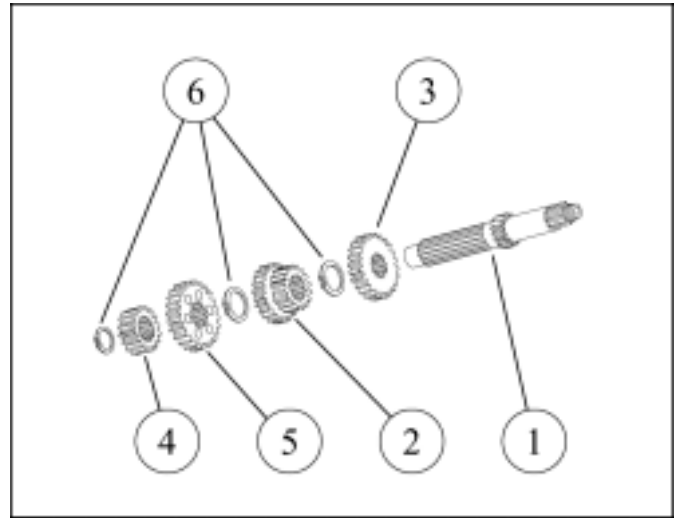

7. Secondary shaft
8. 1st gear pinion
9. 3rd gear pinion
10. 4th gear pinion
11. 6th gear pinion
12. 2nd gear pinion
13. 5th gear pinion
14. Circlips
15. Friction washer

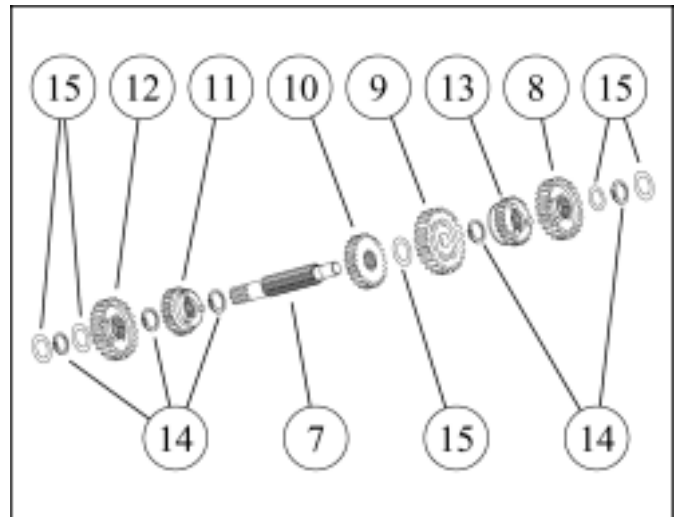

Note: When changing a pinion, we recommend changing the opposite one on the other shaft
The circlips must be renewed each time they are removed.

DISASSEMBLY

To remove the balance shaft

- Remove the balance shaft (1) with the help of a plastic mallet if necessary

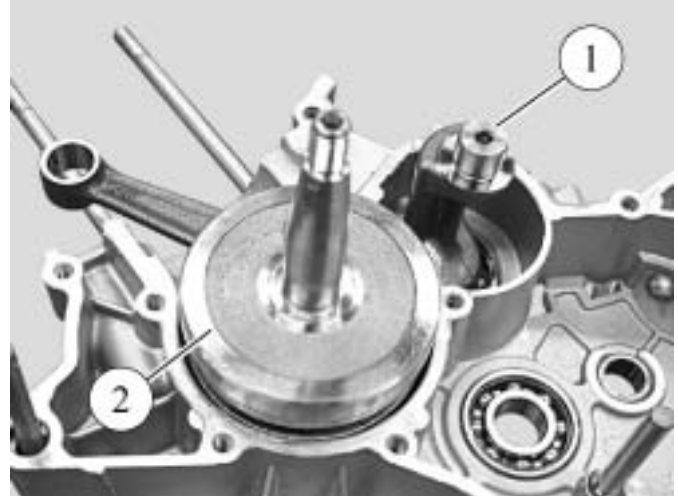

To remove the crank assembly

- Remove the crank assembly (2) with its bush (3) and its O-ring (4) by tapping it lightly on the end with a plastic mallet if necessary

Note: The crank assembly is a free fit in the right-hand casing bearing

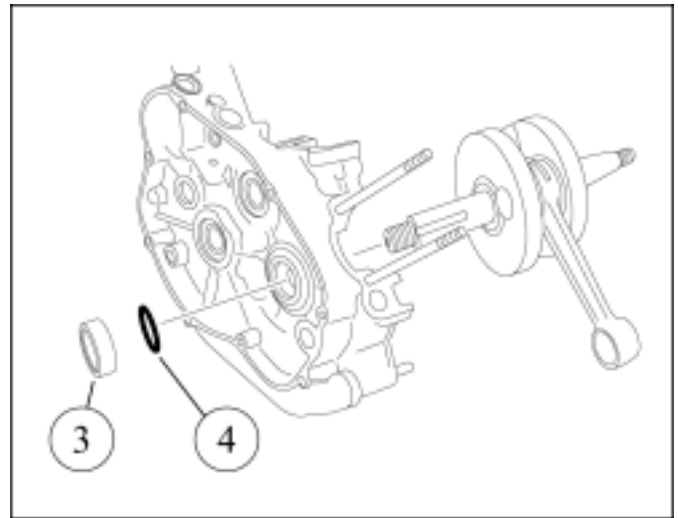

DISASSEMBLY

Checking the crank assembly

- Using a set of shims, check the big end side play
- The maximum side play on the connecting rod end must not exceed: 4/10 mm

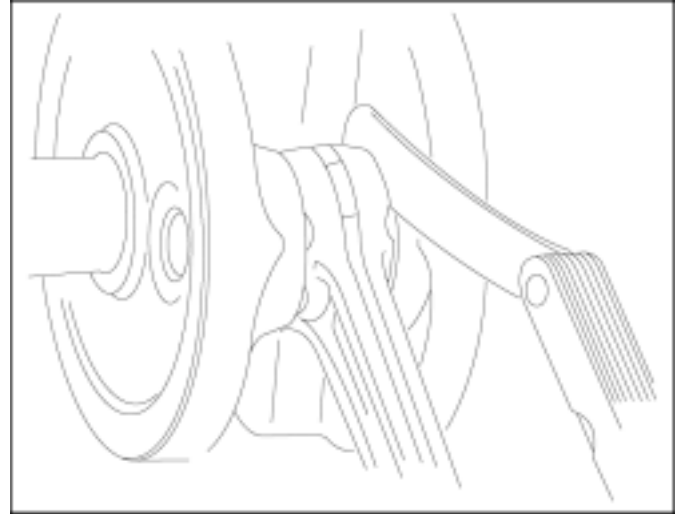

- The out-of-round values measured on the ends of the crank assembly should not exceed 4/100 mm et and must be measured:

- 50 mm on the transmission end
- 50 mm on the magneto flywheel end

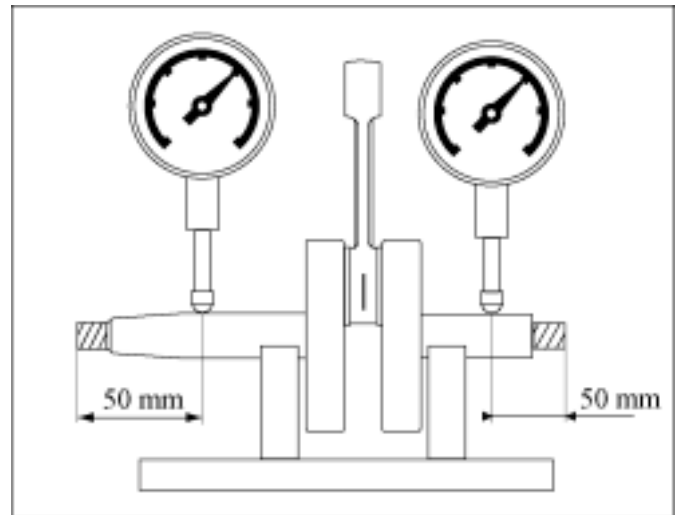

REFITTING SPECIFIC COMPONENTS

To fit the crank assembly bearings

Note:

- The crank assembly bearings and seals must be renewed each time the engine casings are opened
- When the casings are opened, if the bearings stay on the crank assembly, use tool P/N 755585 to remove them
- If a bearing has stuck in the left casing, heat the casing with a heat gun in order to remove it

This operation should be done quickly in order to remove and refit a bearing to the casing

- Set one of the casings on its mating surface, heat it (80 to 90°C) until the bearing drops out of its own accord
- Remove the seal
- While the casing is expanded fit the new bearing fully home in its housing
- Fit a new seal in the left casing using tool P/N 753726

Note: The right hand side seal should be fitted after closing the casings, fitting the O-ring and the bush, in order to prevent the seal lips from being damaged or from turning inside out.

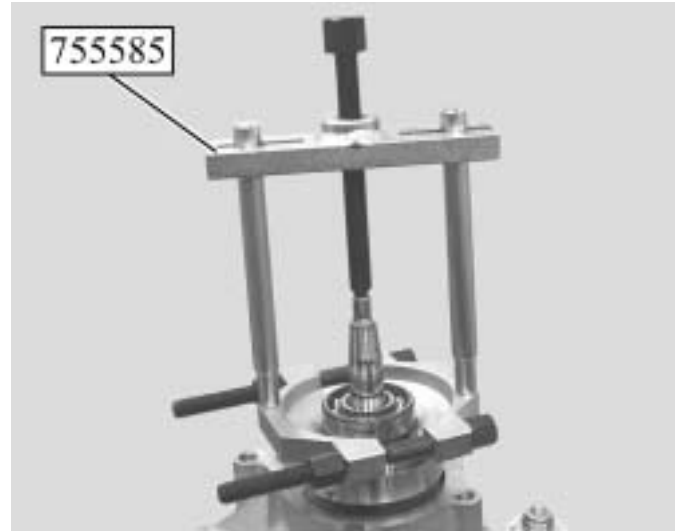

REFITTING SPECIFIC COMPONENTS

To fit the box output seal

- Using tool part number 753726, fit the box output seal



To fit the selector shaft seal

- Using tool part number 753728, fit the selector shaft seal



To fit the clutch lever seal

- Using tool part number 753730, fit the clutch lever seal

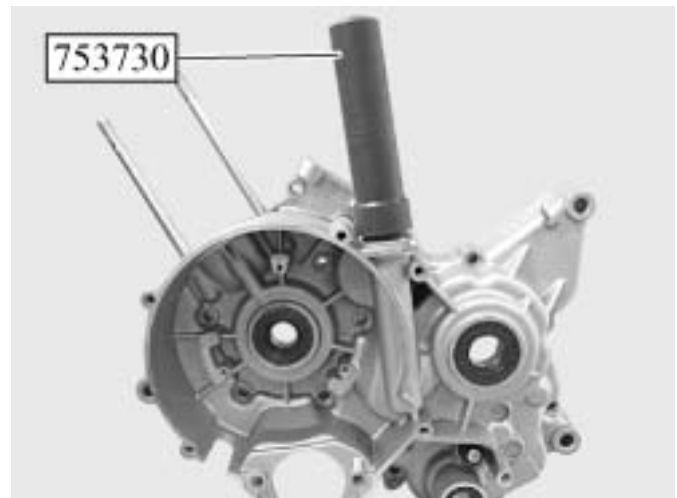

REFITTING SPECIFIC COMPONENTS

To fit the balance shaft

- Fit the balance shaft (1) into the right side casing using a plastic mallet if necessary

To fit the crank assembly

- Fit the crank assembly (2) in the right side casing

Note: The crank assembly is a free fit in the right-hand casing bearing

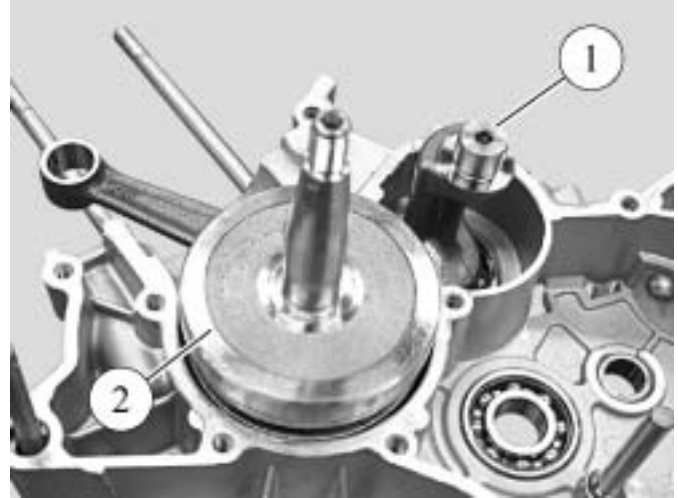

To fit the gearbox

- Fit the slightly greased friction washer (1) onto the needle bearing sleeve on the secondary shaft in the right side casing
- Fit the slightly greased thrust spring and the locking ball (2) into their housing

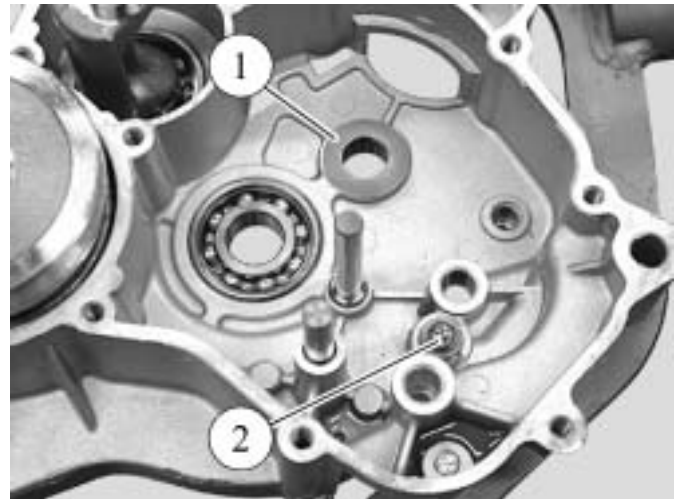

- At the same time fit the secondary shaft and primary shaft assembly with its selector fork (3) into the right side casing

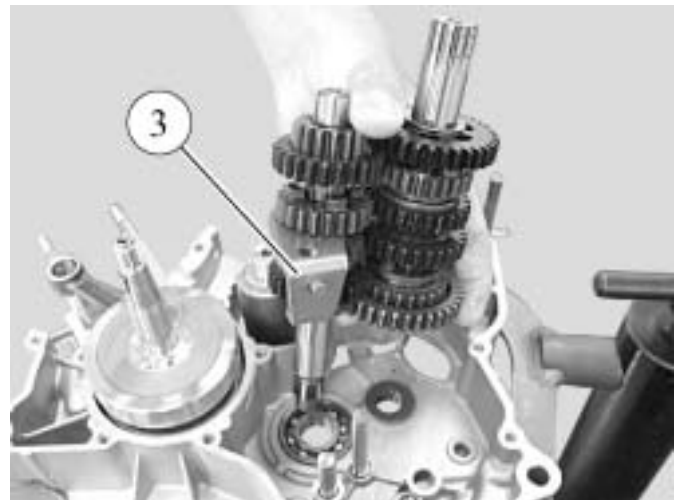

REFITTING SPECIFIC COMPONENTS

- Fit the elbow fork (4) and the 5th gear idler pinion to the secondary shaft



- Fit the selector cylinder with its 2 washers
- Position the fork guide (3) in the selector cylinder intermediate groove

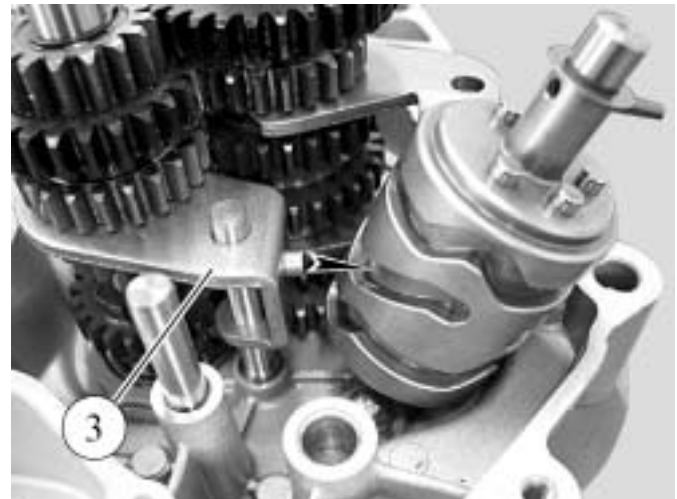

- Fit the fork (5) to the 6th gear idler pinion
- Position the fork guide (4) in the selector cylinder lower groove
- Position the fork guide (5) in the selector cylinder upper groove

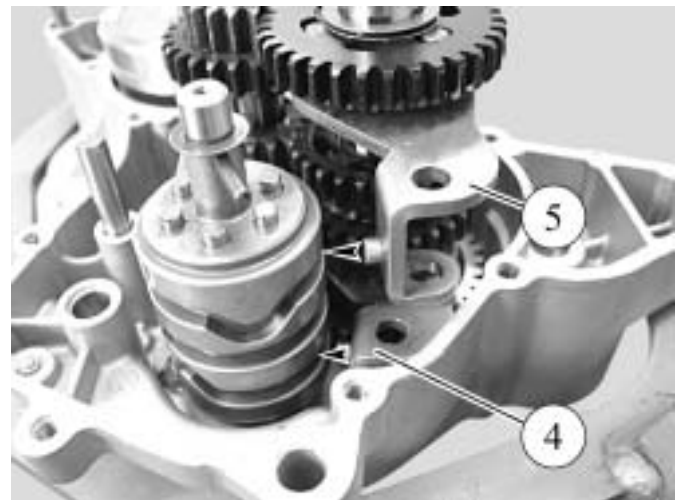

REFITTING SPECIFIC COMPONENTS

- Fit the fork shaft (6)
- Position the selector cylinder in 4th gear, with the mécanindus pin opposite the fork shaft
- Fit the selector shaft (7) fitted with its 2 friction washers



To fit the left side casing

- Check the friction washers are fitted to:
 - the secondary shaft (1)
 - the selector drum (2)
 - the selector shaft (3)
- Fit the 2 centring pins (4)
- Check the right side casing mating surface is absolutely clean
- Coat the right side casing mating surface with gasket compound
- Lightly grease the ends of the shafts

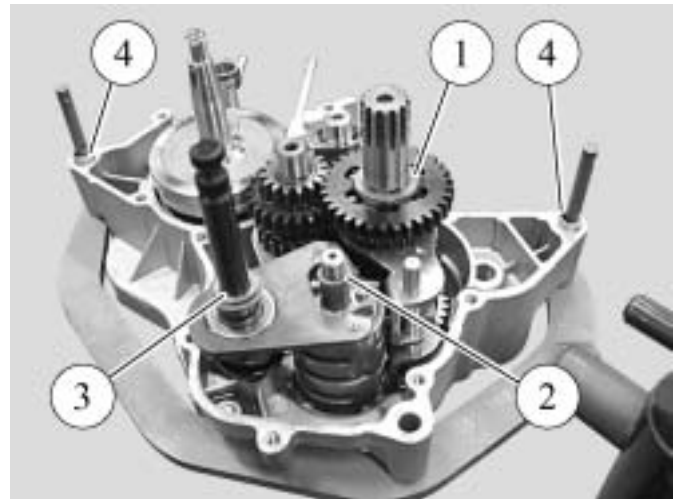

- Check the left side casing mating surface is absolutely clean
- Fit the left side casing
- Tighten pin P/N 750069 on the end of the crank assembly

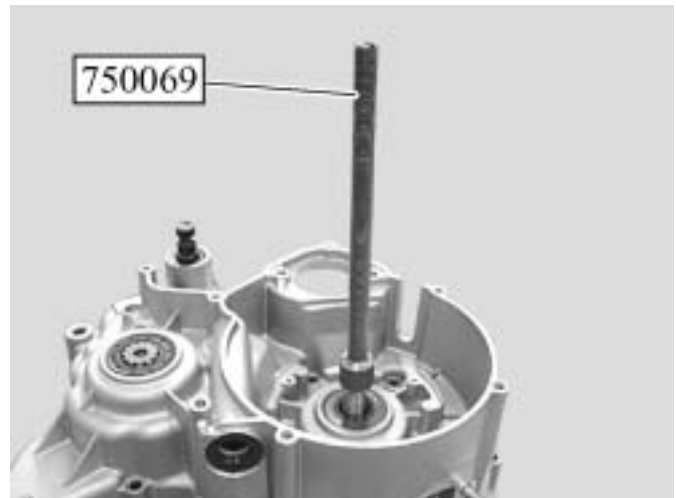

REFITTING SPECIFIC COMPONENTS

- Fit tool P/N 64706 fitted with plate P/N 753708 to the pin
- Centre the assembly on the casing using 4 bolts (5)
- Fit centring tool P/N 64710 to tool P/N 64706
- Tighten pin nut P/N 69104 until the casings are fully closed

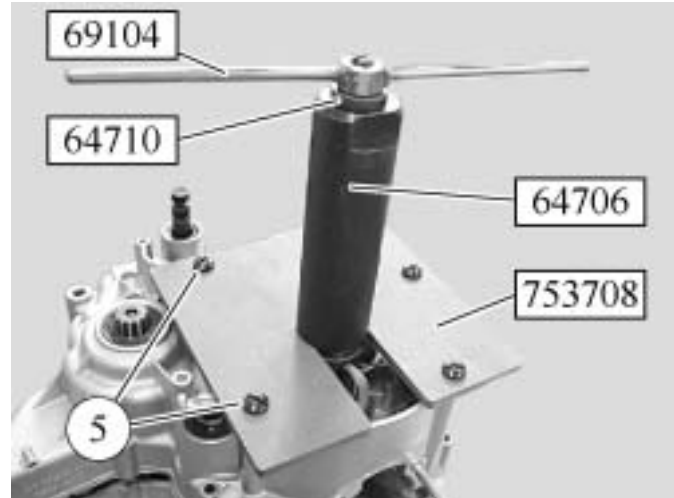

- Fit and tighten the 13 securing bolts
- Tightening torque: 1.1 m.daN

Note: - Check the crank assembly turns freely in the casings

- Fit the gear selector without tightening it, turn the primary shaft manually and check the gears change correctly
- Lightly grease the crank assembly and bearings with 2-stroke oil

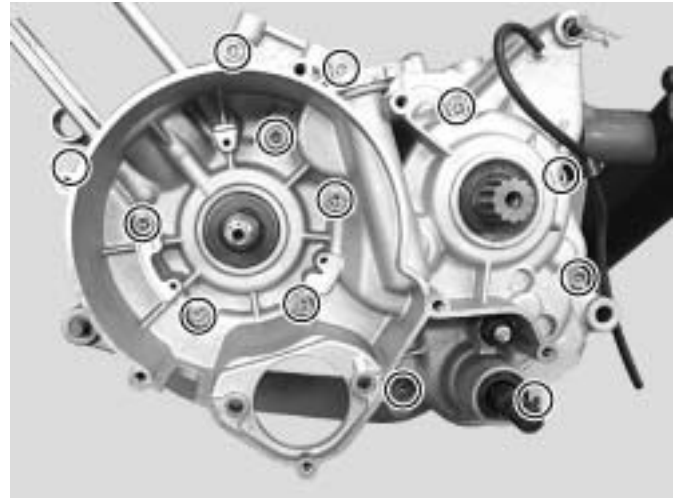

REFITTING SPECIFIC COMPONENTS

To check the piston

- The piston should show no traces of scoring or seizure
- The rings must be free in their grooves

To check the piston rings

- Carefully remove the piston rings
- Place a ring in the bore parallel to it and measure the gap using a feeler gauge
- Piston ring gap: 0.15 mm to 0.30 mm
- Utilisation limit: 1 mm

To fit the piston

- Fit the needle bearing race (1) into the connecting rod little end after lubricating it with 2-stroke oil
- Fit the piston to the connecting rod, the positioning spigots on the piston rings facing the inlet side
- Fit the gudgeon pin
- Fit the circlips using pliers P/N 752000

Important: - The circlips must be changed each time they are removed
The circlip gaps must face upwards or downwards (2), but under no circumstances to the side

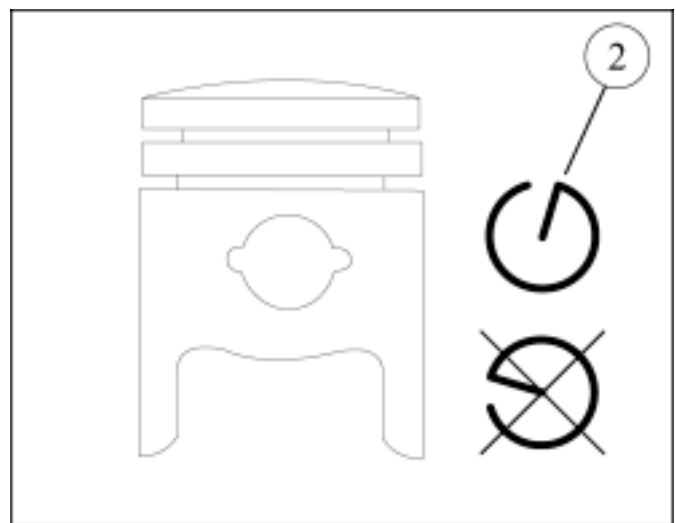
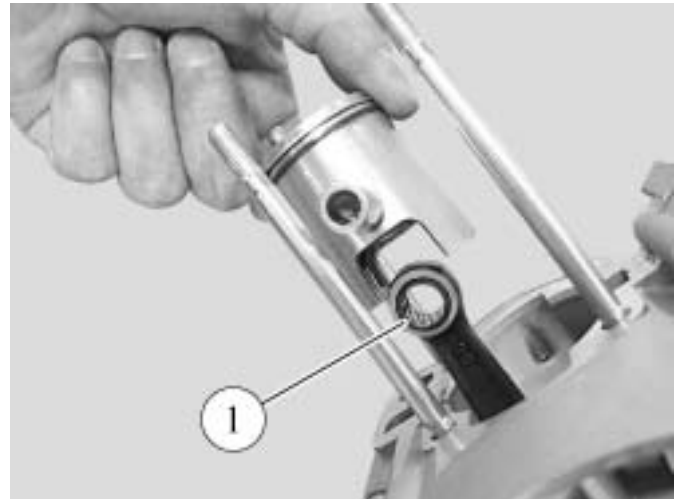
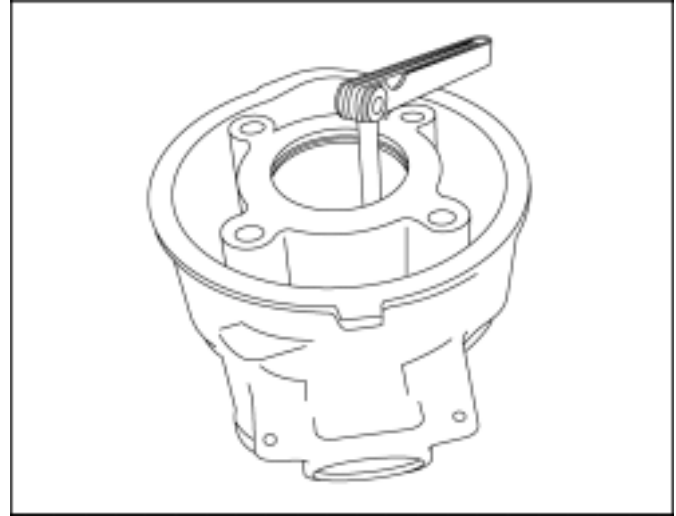

REFITTING SPECIFIC COMPONENTS

To fit the cylinder

- Fit a new base gasket (1) do not use oil or grease
- Ensure that the piston ring gaps are opposite the piston positioning spigots
- Fit the cylinder (2) and insert it while compressing the piston rings by hand
- Fit the cylinder over the piston by compressing the piston rings by hand

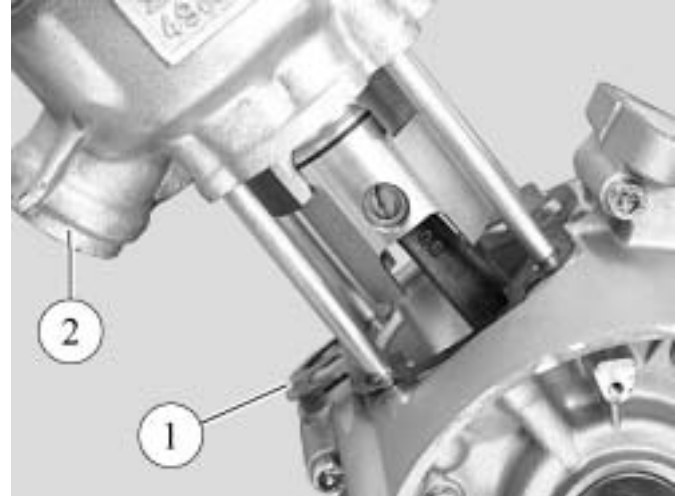

To fit the cylinder head

- Check the O-ring housings are absolutely clean
- Fit the new O-rings to the cylinder head
- Fit the cylinder head to the cylinder
- Tighten the cylinder head securing nuts working diagonally in 2 or 3 steps
- Tightening torque: 1.8 m.daN
- Fit the spark plug
- Tightening torque: 2.5 m.daN

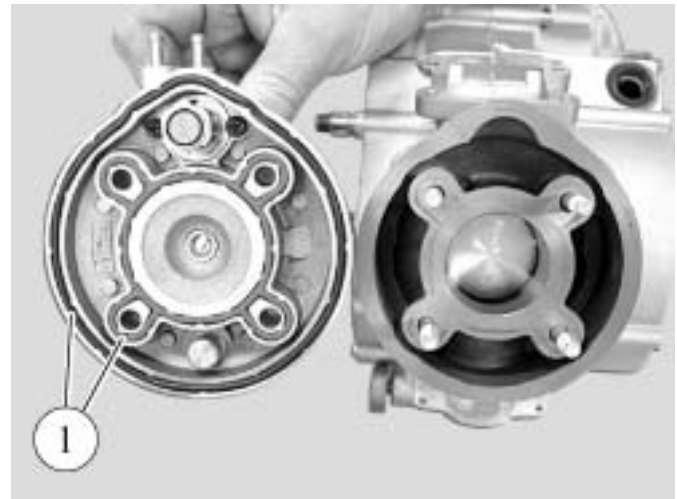

To fit the right side O-ring

- Fit a new O-ring (1) and spacer (2) to the crank assembly

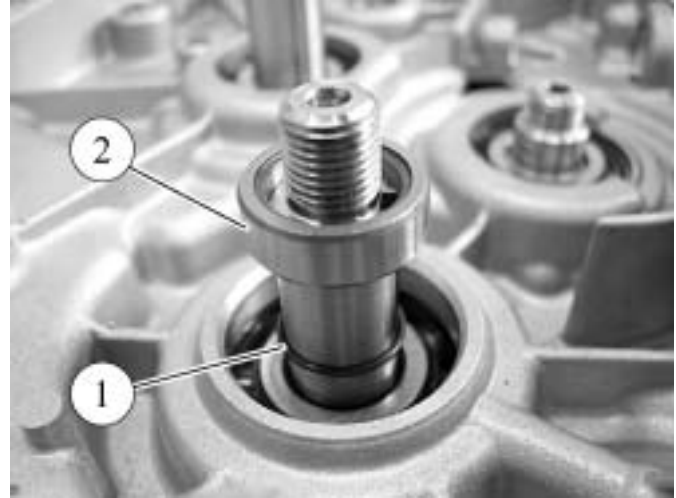

- Using tool part number 753726, fit a new O-ring (3), with the lip facing outwards



To fit the crank assembly and balance shaft pinions

- Fit key (1) into the crank assembly housing
- Fit the key (2) into the balance shaft housing



REFITTING SPECIFIC COMPONENTS

- Fit the crank assembly pinion (3), with the marked tooth to the outside
- Fit the balance shaft pinion (4) by lining up the tooth gap marked with two spots (A) with the mark of on spot (A) on the crank assembly pinion
- Fit the nut but do not tighten it
- Lock the balance shaft using a bolt (B) inserted into one of the threaded holes
- Turn the balance shaft pinion to bring the bolt into contact with a ribbing on the casing
- Tight the balance shaft nut (5)
- Tightening torque: 6 m.daN



- Fit the pinion (6), with the spotfacing towards the outside, and fit nut (7)
- Tighten the crank assembly pinion
- Tightening torque: 7.5 m.daN

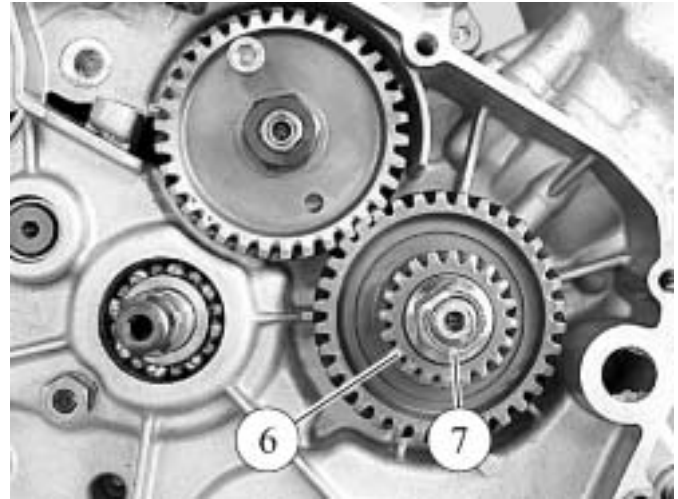

REFITTING SPECIFIC COMPONENTS

To fit the clutch

- Fit the following to the primary shaft:
 - the tapered washer (1) with the round end towards the bearing
 - the plain washer (2)
 - the clutch housing (3)
 - the splined bush (4)
 - the clutch main shaft (5)
 - the tab washer (6) and the nut (7)

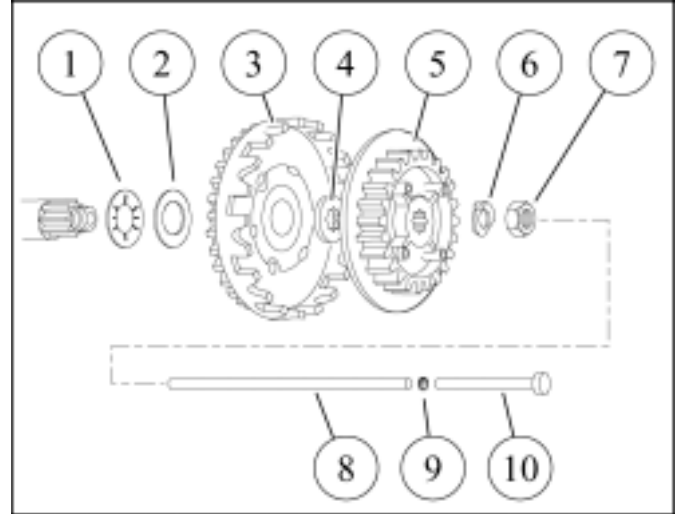

- Lock the clutch main shaft with tool P/N 753731
- Tighten the nut
- Tightening torque: 7.5 m.daN
- Fold over the clutch nut washer locking tab
- Fit the clutch control lever with its spring and washer
- To the primary shaft, fit the piston (8), the ball (9) and thrust rod (10)

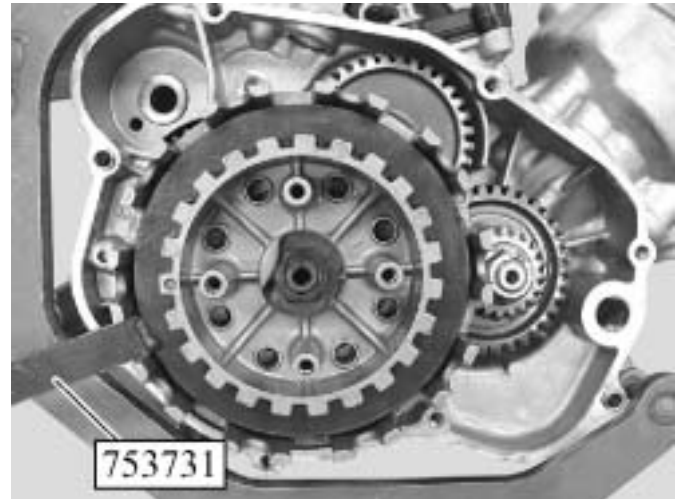

- Fit the clutch discs starting with a lined disc (11) and then alternate smooth and lined discs (12)

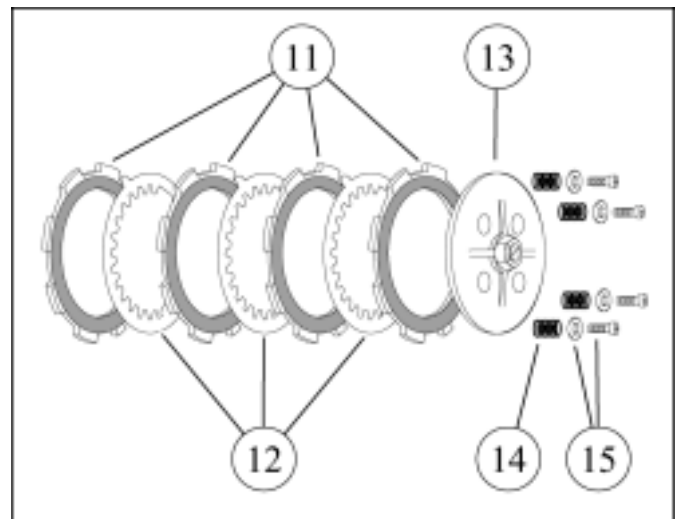

REFITTING SPECIFIC COMPONENTS

- When re-assembling, ensure that the marks (A) on the smooth discs are offset by 120° from the others



- Fit the pressure plate (13) lining up the arrow (B) on the plate with the round imprint (C) on the clutch main shaft
- Fit the pressure plate springs (14) and the 4 bolts and washers (15)
- Tightening torque: 0.5 m.daN

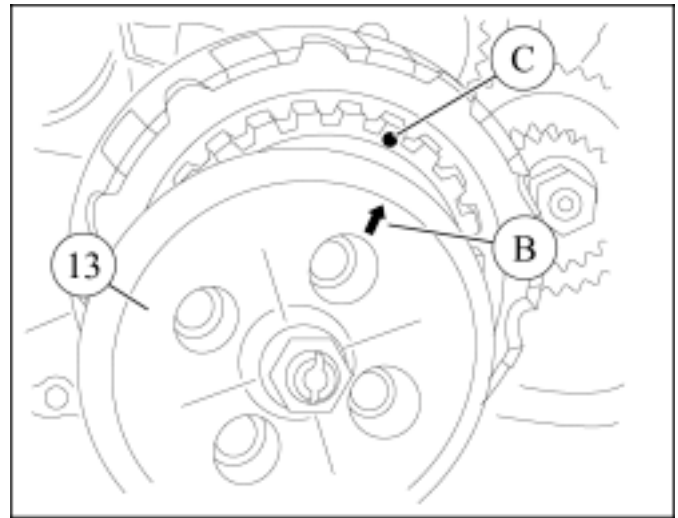

REFITTING SPECIFIC COMPONENTS

To adjust the clutch control lever

- Slacken the pressure plate locknut (1)
- Bring the lever into contact with the control rod
- Turn the centre bolt (2) on the pressure plate in order to set the control lever at 30° to the magneto flywheel cover mating surface
- Tighten the locknut without altering the adjustment
- Tightening torque: 2.7 m.daN

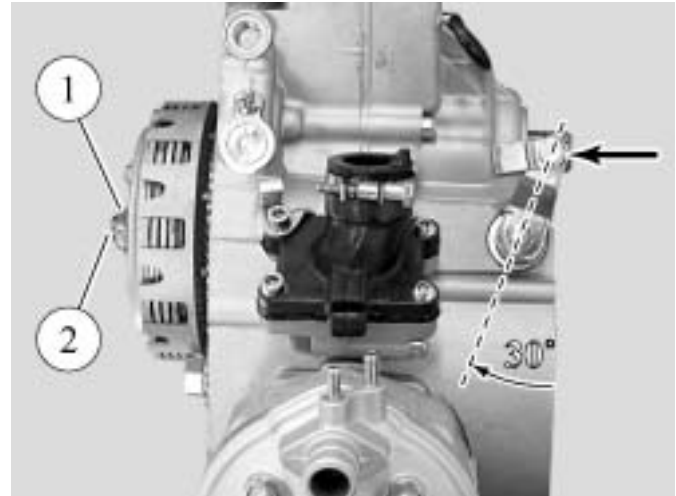

To fit the starter system (depending on model) and the clutch cover

- Fit the spring (1) to the starter shaft- Fit the spring (1) to the starter shaft
- Fit the starter dog (2), the starter release mechanisms (A) lining up with the return spring arm (B)
- Fit the starter motor dog (3)

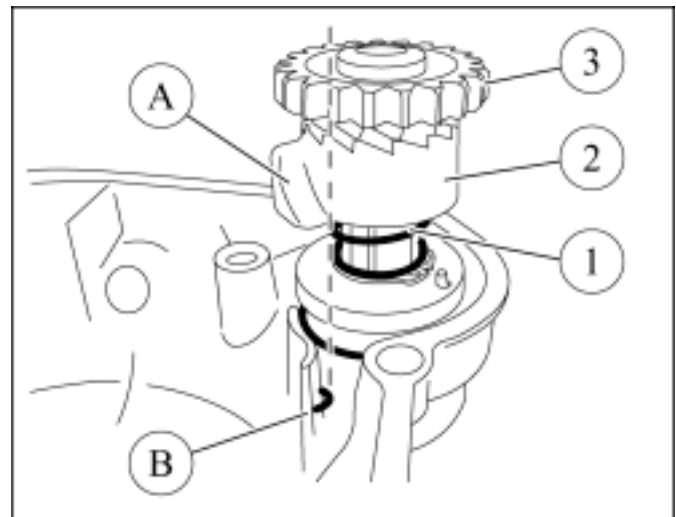

- Fit the 2 locating pins and a new paper gasket
- Fit the clutch cover, turn the crank assembly by hand, if necessary, to mesh the water pump pinion with the crank assembly pinion
- Fit the cover 8 fixing bolts
- Tightening torque: 1.1 m.daN
- Fit and gently operate the kickstart pedal and hold it in position
- Fit the kickstart shaft bump stop
- Tightening torque: 3 m.daN
- Release the kickstart pedal



To fit the magneto flywheel

- Fit the stator assembly
- Fit and tighten the stator assembly (2) two fixing bolts (1)
- Tightening torque: 0.3 m.daN

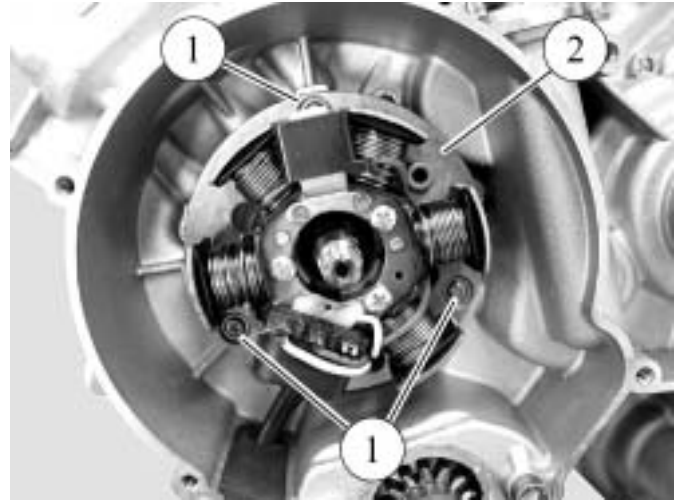

- Fit the rotor (3) to the crank assembly ensuring it is positioned on the key
- Lock the rotor with the adjustable pin wrench P/N 752237
- Fit and tighten the rotor nut
- Tightening torque: 5.2 m.daN
- Fit the gasket and the magneto flywheel cover
- Tightening torque: 0.4 m.daN

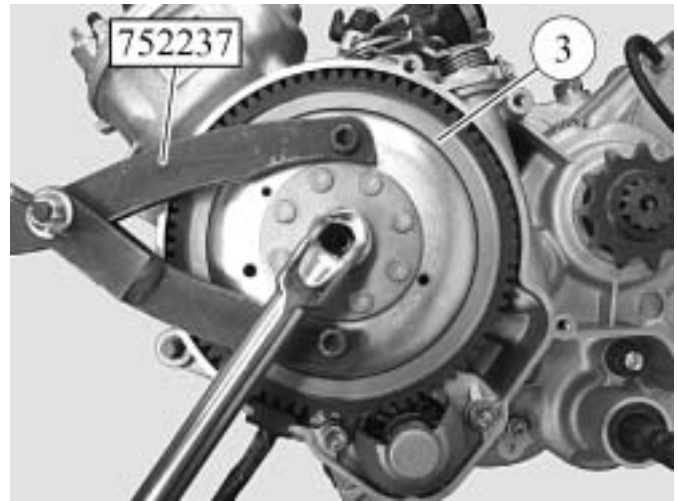

MISCELLANEOUS OPERATIONS

To remove the water pump

- Remove the clutch cover 8 fixing bolts
- Remove the clutch cover
- Remove the water pump cover (1) 2 fixing bolts
- Remove the cover
- Remove the two centring pillars and the paper gasket (2)

From inside the clutch cover, remove:

- the circlip (3)
- the washer (4)
- the 30-tooth nylon pinion (5)
- the drive pin (6)
- the washer (7)
- the impeller with its shaft (8)
- the seal (9)

- Check the condition of the impeller shaft, if it is shows signs of wear, change the impeller

To fit the water pump

- Using fitting tool P/N 753729, fit a new lightly greased gasket (9)
- Re-assemble in the reverse order to disassembly

Note: A new circlip and paper gasket must be used each time they are removed

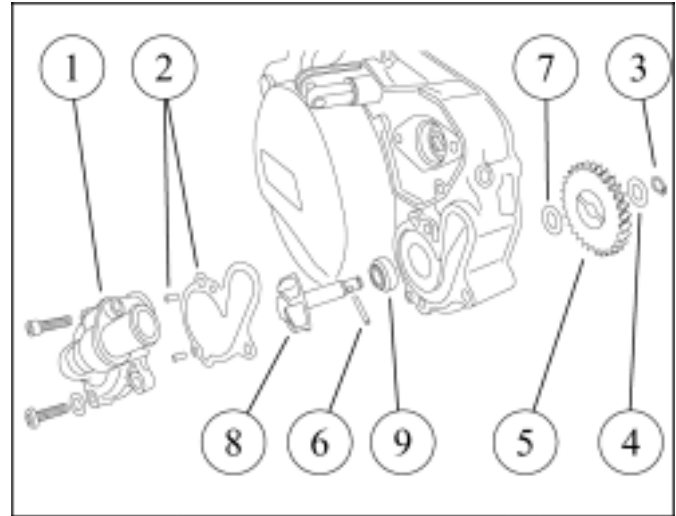

MISCELLANEOUS OPERATIONS

To remove the oil pump and its drive pinions

- Remove the clutch cover 8 fixing bolts
- Remove the clutch cover
- Remove the oil pump cover
- Remove the oil pump two fixing bolts
- Remove the pump (1) with its O-ring

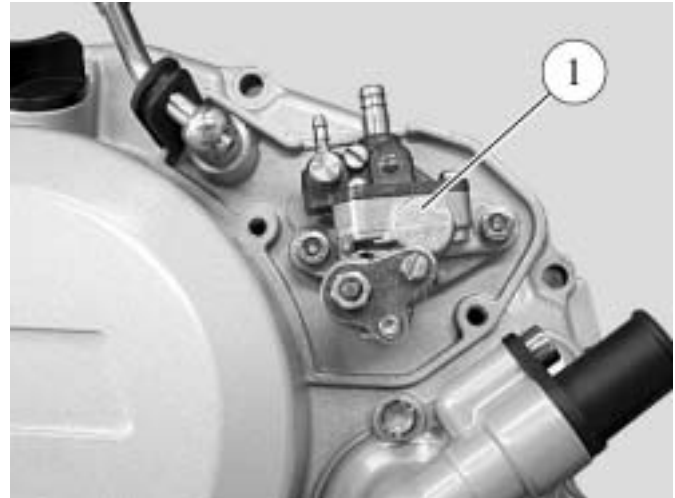

From inside the clutch cover, remove:

- the 2 circlips (2)
 - the pinion (3)
 - the drive pin (4)
 - the washer (5)
 - the pump shaft and its washer (6)
 - the pinion with its 2 washers (7)
- Check the condition of the oil pump shaft, if it shows signs of wear, change the shaft

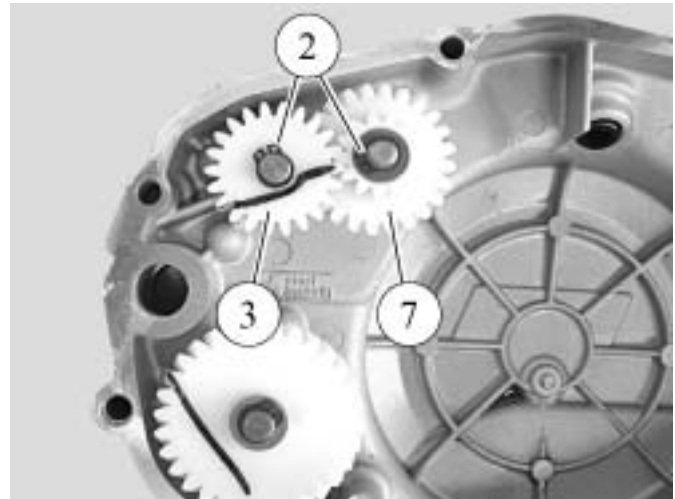

To fit the oil pump

- Lubricate the 2 shafts
- Re-assemble in the reverse order to disassembly

Note: New circlips and O-ring must be used each time they are removed

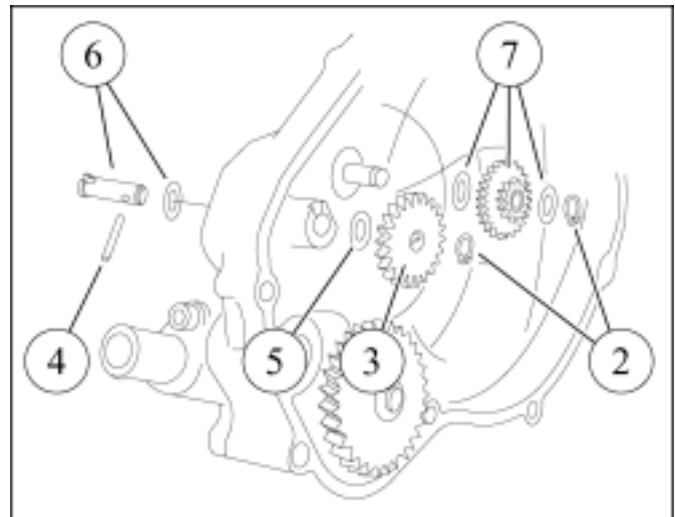



PEUGEOT
Motocycles

RECOMMENDED



 **UTAC**
CERTIFICATION
SYSTEMES QUALITE
ISO 9001
Certificat n° SQ/766

REF: 757068

For reasons of continuous improvement, Peugeot Motocycles reserves the right to modify, delete or add any part number quoted DCDC/PS/ATR printed in EU 02/2002 (photos non-contractual)